

AIT AUSTRIAN INSTITUTE OF TECHNOLOGY

R&D Summit - Mensch und Maschine

28.11.2022

Fachverband Metalltechnische Industrie

Fachverband der Elektro- und Elektronikindustrie

Christian Chimani



BMK

1.400
employees

7 Centers

Austria's largest
RTO

Infrastructure Systems

System
Competence

Applied Research

Next Generation
Solutions

4 Subsidiary
Enterprises

Federation of
Austrian Industries
(through VFFI)

LKR, NES, SL, Profactor 51%

176
m EUR total revenue

Tomorrow Today



AIT AUSTRIAN INSTITUTE OF TECHNOLOGY



AIT AUSTRIAN INSTITUTE OF TECHNOLOGY

OWNERSHIP STRUCTURE

49.54 %

**FEDERATION OF
AUSTRIAN INDUSTRIES**
(through VFFI)

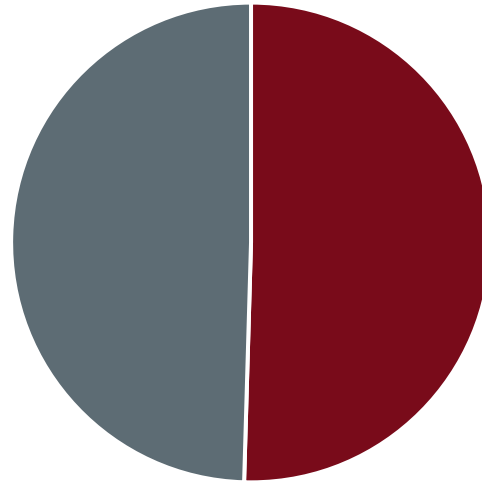

50.46 %

REPUBLIC OF AUSTRIA

Federal Ministry for Climate Action, Environment,
Energy, Mobility, Innovation and Technology

1.400

EMPLOYEES

176 m EUR

TOTAL REVENUES
as of YE 2021

97,0 m EUR Contract research revenues (incl. grants)

50,8 m EUR BMK funding

24,0 m EUR Other operating income,
incl. Nuclear Engineering Seibersdorf

4,3 m EUR Profactor (51%)

CENTER FOR ENERGY

Integrated Energy Systems

Integrated Energy Systems

Integrated Transport Optimisation

Electric Energy Systems

Power System Planning & Operation

Hybrid Power Plants

Power System Digitalisation

Power Electronics & System Components

Sustainable Thermal Energy Systems

Efficiency in Industrial Processes & Systems

Digitalisation & HVAC Technologies in Buildings

PS

Energy Conversion & Hydrogen

Energy Conversion & Hydrogen

Digital Resilient Cities

Smart and Carbon-neutral Urban Development

Integrated Digital Urban Planning

Climate Resilient Urban Pathways

PS

PS Principal Scientists

CENTER FOR HEALTH & BIORESOURCES

„ONE HEALTH“ KONZEPT

Die Gesundheit des Menschen, der Tiere und des Ökosystems sind miteinander verbunden und voneinander abhängig. Das One Health-Konzept bedeutet einen Paradigmenwechsel weg von einer isolierten Betrachtungsweise der einzelnen Systeme hin zu einem holistischen Ansatz.

Unsere Themen und Alleinstellungsmerkmale

HEALTH CARE

- Nicht- und minimal-invasive Molekular Diagnostik (chronische und Infektionskrankheiten)
- Medizinische Datenanalyse
- Telehealth Lösungen
- Therapieunterstützung und Rehabilitation
- Prädiktive Gesundheitsinformationssysteme
- Gesundes Leben und Altern

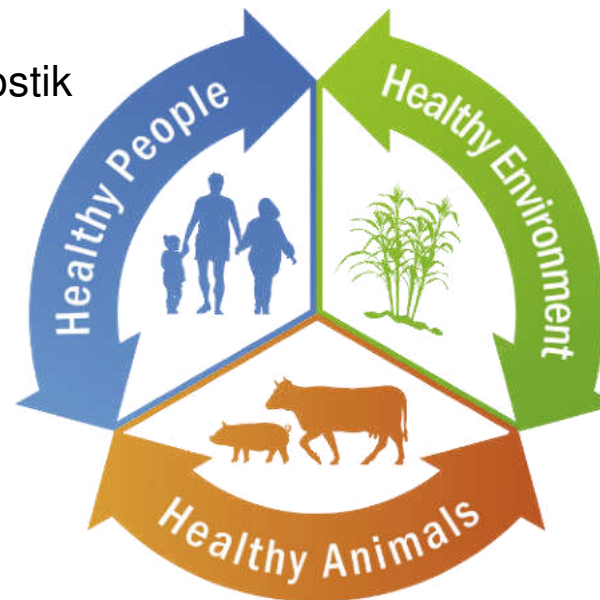

BIOECONOMY

- Verbesserte Pflanzensysteme
- Pflanzen-Mikrobiominteraktionen
- Mikrobiom-basierte Nutzpflanzenproduktion
- Schädlingsbekämpfung (Biopestizide, Biodünger...)
- Verbesserte Nahrungsmittelqualität und -sicherheit
- Gesunde Nahrungsmittel für gesunde Lebewesen

CENTER FOR DIGITAL SAFETY & SECURITY

FÜHRENDE SICHERHEITSLÖSUNGEN (AUSZUG)

Sensing & Vision Solutions	Cooperative Digital Technologies	Data Science & Artificial Intelligence	Cyber Security
Digitale Identität	Lagebild- und C2 Systeme	OSINT, LEA Tools	Kritische Infrastrukturen
Border Management	Krisen und Disaster Management	Forensik virtuelle Währungen	Threat Intelligence, Verschlüsselung

- Sensor Systeme
- Sensor Fusion
- Digitale Identität
- Responsible use of critical Data

- Datenräume und Datenmarktplätze
- IT Interoperabilität
- Middleware Systeme
- Data Sharing – Gaia-X

- Digitalisierte Produktionsprozesse
- Predictive Maintenance
- Explainable AI
- Testen und Verifikation von AI Systemen
- Big Data Management (Bild, Video, Audio, Text, Sensordaten)

- Schutz digitaler Infrastrukturen und Produktionssysteme, IT/OT Cyber Security
- Security by Design
- Secure Backup Systeme
- Smart Encryption, Post-Quantum Verschlüsselung
- Training & Ausbildung

- 200+ Expert:innen (Master, 1/3 PhD): 51% Scientists, 39% Engineers, 10% Admin



CENTER FOR VISION, AUTOMATION & CONTROL

Agile & sustainable manufacturing of high-quality products



Mechatronic
Systems



Robotic & Autonomous
Systems



Inspection & Metrology
Systems



Manufacturing
Systems

Process automation & optimisation

- Reduction of material scrap and thus of material input
- Use of secondary raw materials (recycling)
- Reduction of fossil & mineral raw materials
- Use of hydrogen & renewable energy
- Manufacturing of new high-quality products for lightweight construction

INNOVATION SYSTEMS & POLICY



INNOVATION SYSTEMS & DIGITALISATION

Analyse von neuen Formen der Innovation für ein besseres Verständnis der Entstehung sowie der Auswirkungen neuer Technologien



INNOVATION DYNAMICS & MODELLING

quantitative Analyse und Modellierung von Innovationssystemen und deren Dynamik



SOCIETAL FUTURES

Erforschung radikal differenterer Zukünfte, die als gesellschaftlicher Kontext für eine transformative Innovationspolitik dienen



INNOVATION POLICY & TRANSFORMATION

Unterstützung, Beratung und Begleitung von Entscheidungsträger:innen der Forschungs- Technologie- & Innovationspolitik von der Strategieentwicklung bis zur Umsetzung

CENTER FOR TECHNOLOGY EXPERIENCE: NEXT GENERATION HUMAN CENTRICITY



EXPERIENCE CAPTURING

Situationen, Bedürfnisse und User verstehen sowie Potentiale aus Experience Sichtweise erkennen

- Automation Experience & Human in the Loop
- Contextual Persuasion
- Engagement Strategies
- Challenging Environments



EXPERIENCE MEASUREMENT

Experience Messung, Definition, Modellierung und Optimierung

- Experience Assessment, Optimization & Acceptance
- Digital Skills & Learning
- Diversity, Social Experience, Accessibility
- Multilevel Measurement



HUMAN CENTERED BUSINESS INNOVATION

Business Potentiale aus Experience Sichtweise identifizieren und methodisch entwickeln

- Experience Thinking
- Experience Leadership
- Next Generation Methods
- Experience Innovation Labs



FUTURE INTERFACE DESIGN

Neue Technologien ermöglichen neue Interface Konzepte

- Hybrid Worlds (VR, XR)
- Augmented Humans
- Industrial Human Machine Interfaces (HMI)
- Intelligent Interfaces & Human-AI Interaction (inkl. HRI)

CENTER FOR LOW-EMISSION TRANSPORT

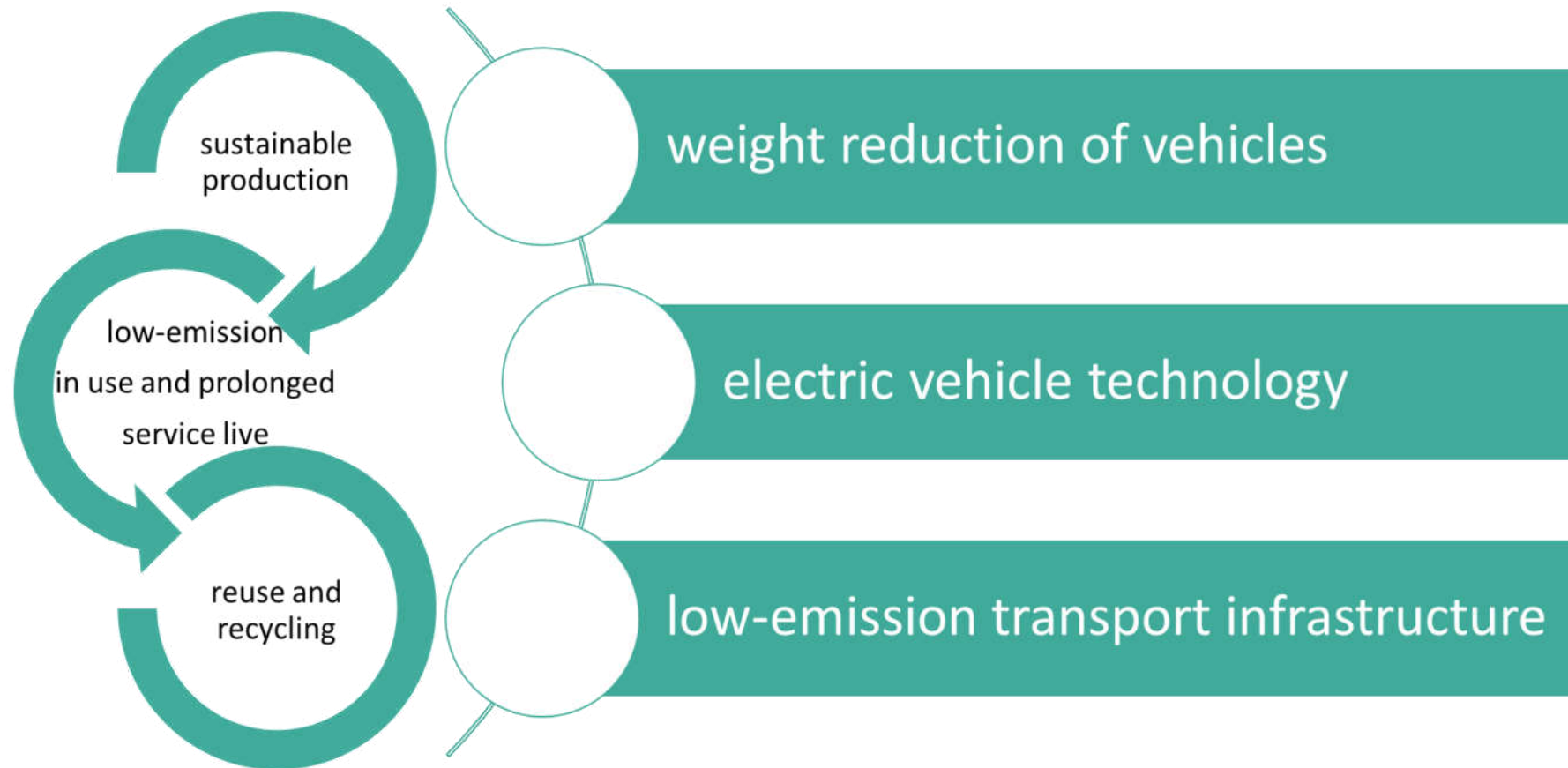

Overview of LET centers focus topics and addressed systems

AUSGEWÄHLTE BEISPIELE FÜR NACHHALTIGKEIT BEI METALLISCHER WERKSTOFF- UND PROZESSENTWICKLUNG



MAGNESIUM ALLOYS WITH REDUCED OXIDATION TENDENCY

- **Aims:**

- Simplified handling (reduced oxidation tendency)
- Process capable (HPDC, Thixomolding, extrusion, heat treatment,...)
- Meets the requirements of aviation agencies regarding non-flammability
- Good mechanical properties

- **Approach:**

- Modification of commercially available „standard“ alloys like AZ31, AZ80, AZ91 and AM60
- Purposeful addition of selected alloying elements e.g. calcium (Ca), yttrium (Y), strontium (Sr), manganese (Mn),...

AZ91CaY



Testdauer ab Brenner Start

30 Sek.

90 sek.
(Brenner aus)

120 Sek.

AZ91



ALLOY DEVELOPMENT: 7XXX-ALLOYS

- High-strength 7xxx alloys (7075 is an Al-Zn-Mg-Cu alloy, which is not considered weldable in the literature due to its susceptibility to hot cracking) processed in wire-based 3D printing for the first time and excellent mechanical properties achieved thanks to low porosity ($\approx 0.36\%$)

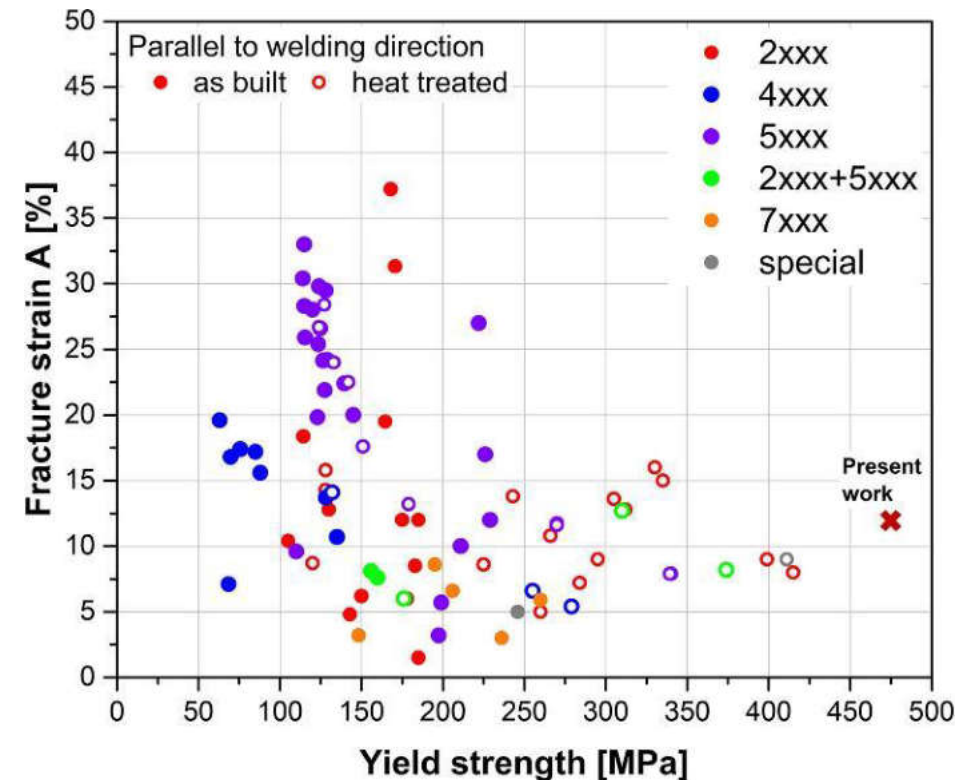

Comparison of mechanical properties (yield strength and elongation at break) of the latest LKR results with literature data.

HIGH PRESSURE DIE CASTING

Frech DAK 1100-112 cold chamber high pressure die casting machine

- 1200 t clamping force
- Crucible volume \approx 350 kg Al / 300 kg Mg
- Vacuum dosing system up to 5 kg melt
- Vacuum pump system
- Various dies for material characterization

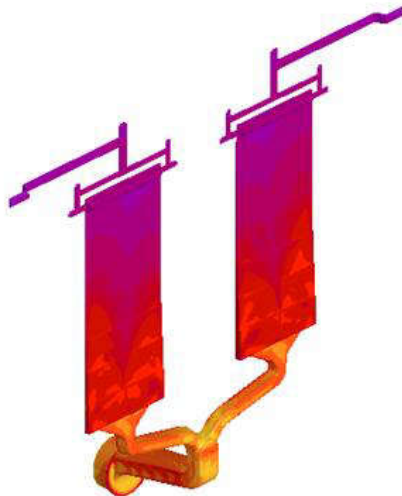

NEFI – NEW ENERGY FOR INDUSTRIE

- Decarbonizing the Industry – **Aluminium High Pressure Die Casting**
 - Casting parts (approx. 300° C) are cooled at in water bath at approx. 20 ° C
 - Improved cooling Waste heat available at 200-300° C for e.g.,
 - Preheat aluminum ingots for melting furnace
 - Preheat mold
 - Solution heat treatment
 - **Up to 30 % reduction of energy possible**

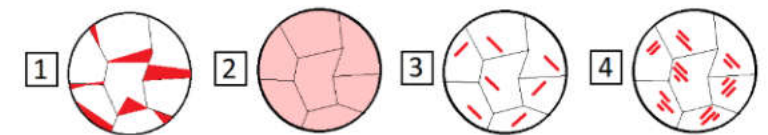
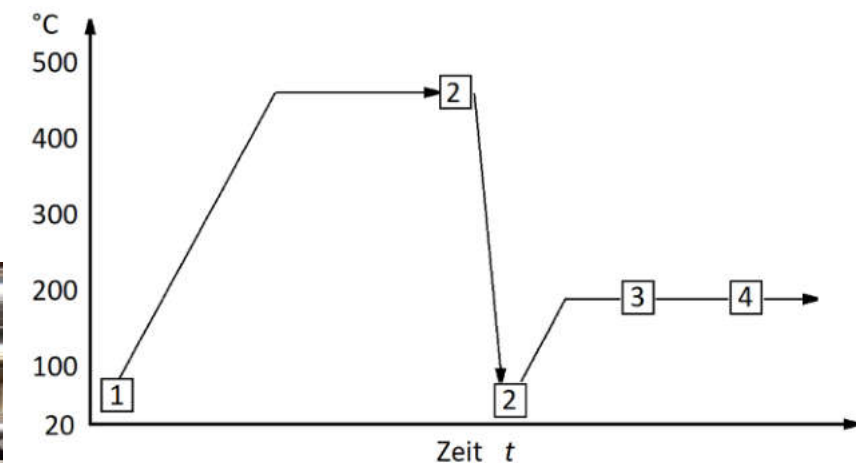
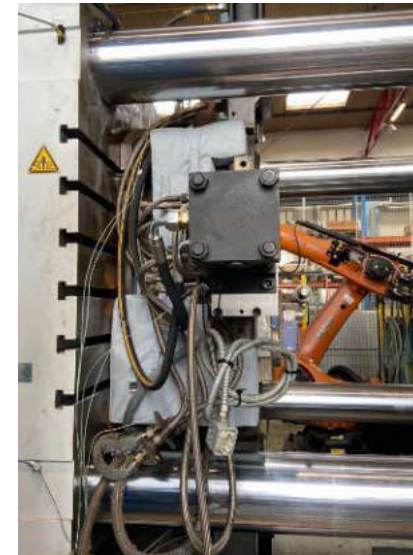

Solution heat treatment

EXTRUSION OF MAGNESIUM AND ALUMINIUM

- 1.5 MN extrusion press for direct and indirect extrusion
- Diameters 0.8 – 35 mm possible
- Heat treatment furnaces

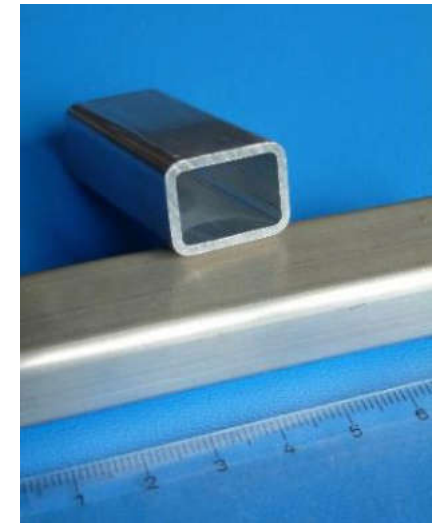

FORGING OF MAGNESIUM

- Hydraulic presses up to 160 t
- Forming temperature range from -180°C to $+500^{\circ}\text{C}$



Forged Mg
connecting rod

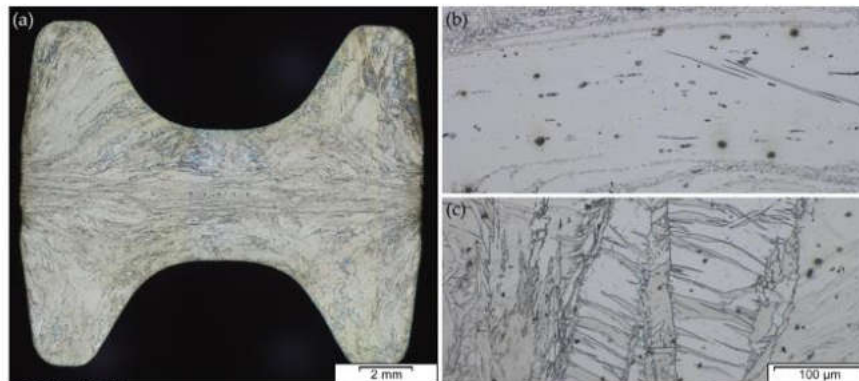

Microstructure of forged
Mg-Al-Ca-Zn alloy

- a) cross section
- b) sample center
- c) sample rim

ENERGY EFFICIENT FORGING OF ALUMINIUM

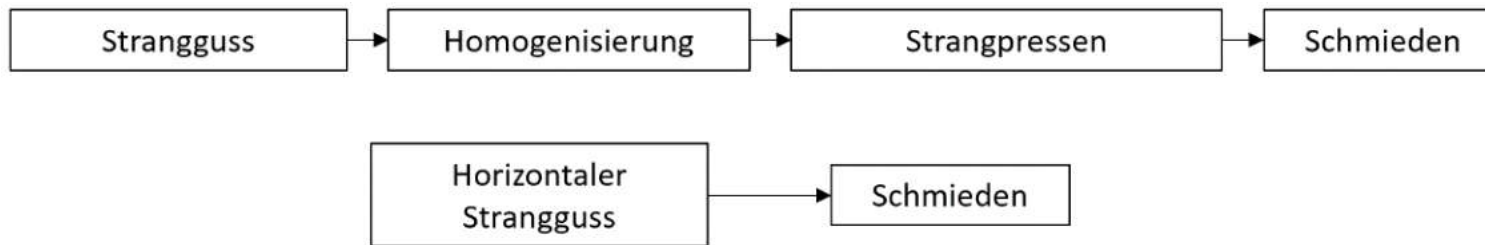

Oben: konventionelle Prozesskette des Schmiedens von Aluminium Fahrwerk-Bauteilen in der Automobilindustrie
 Unten: Angestrebte Prozessketten-Optimierung im Amalfi-Projekt

Increasing energy efficiency by skipping energy intensive production steps like homogenization.

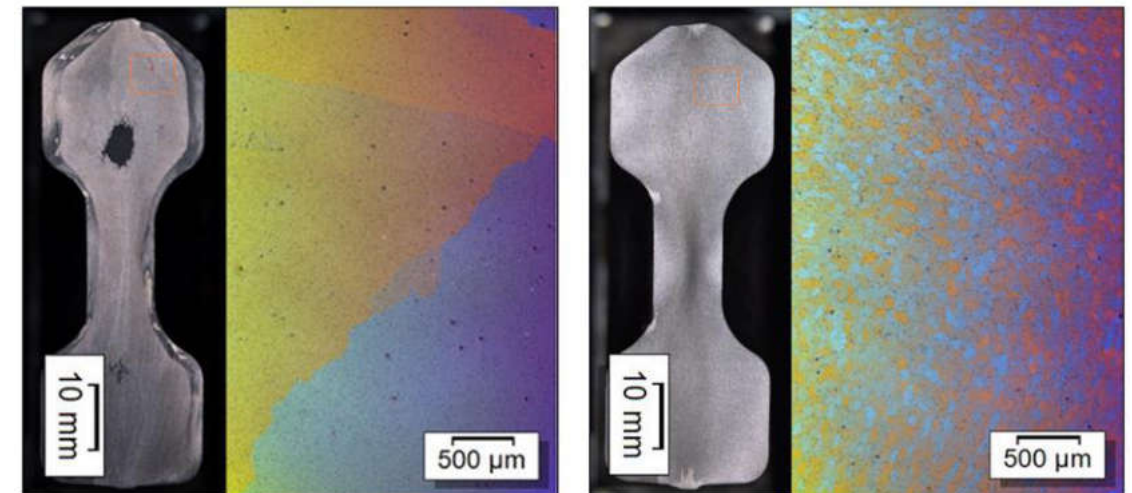

Das Gefüge der orangemarkierten Bereiche ist im rechten Teil der Abbildungen dargestellt.
 Links: Querschnitt des Schmiedebauteils, welches mittels stranggepresstem Vormaterial hergestellt wurde.
 Rechts: Querschnitt des Schmiedebauteils, welches mit optimiertem Vormaterial direkt nach dem Strangguss produziert wurde.

3D ROLLFORMING OF LIGHT METALLS

- 3D roll forming decreases buy-to-fly ratio and process time significantly.
- 10 – 15 m/min

voestalpine
ONE STEP AHEAD.

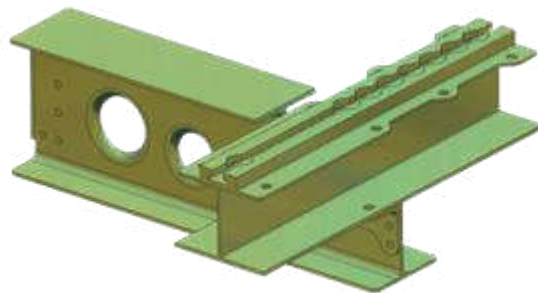
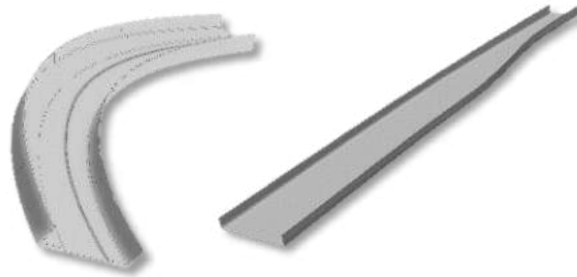

Current floor grid design

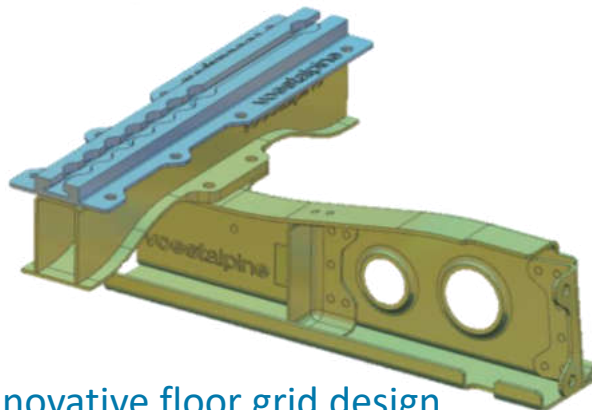

Innovative floor grid design

- » Light weight roll-formed sections and tubes
- » Flexible rollforming (thickness, height)
- » Hybrid seattrack solutions

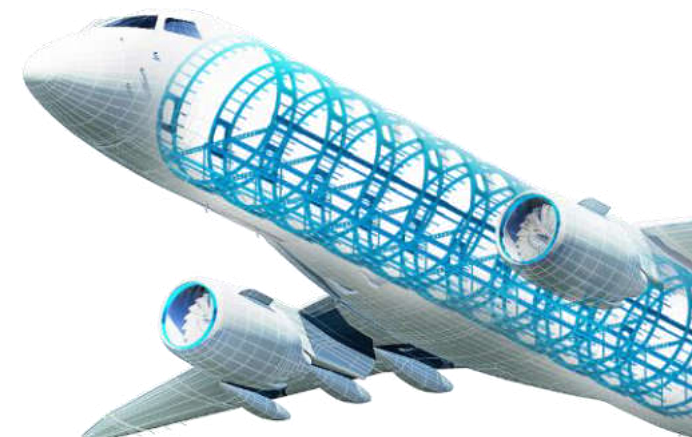

WIRE-BASED ADDITIVE MANUFACTURING

- **„Big parts“ AM-Technologie**
 - Origin in multi-pass welding
 - CAD/CAM+Robotics+WAAM combined
 - High deposition rates
 - Large part sizes >0.4 x 0.4 x 0.4 m³

- **Wire-AM LABORATORY LKR**
 - MIG / MAG / WIG ArcTIG power sources
 - CMT / CMT+ (single- / multi wire feed)
 - Plasma sources
 - 2 automated handling systems
 - ABB – 6 axis + 2 rotation axis
 - KUKA – 6 axis + 2 rotation axis
 - Shielding gases/media incl. mixing station
 - IBA data acquisition system for
 - Multiple sensor integration
 - Diverse sensing approaches

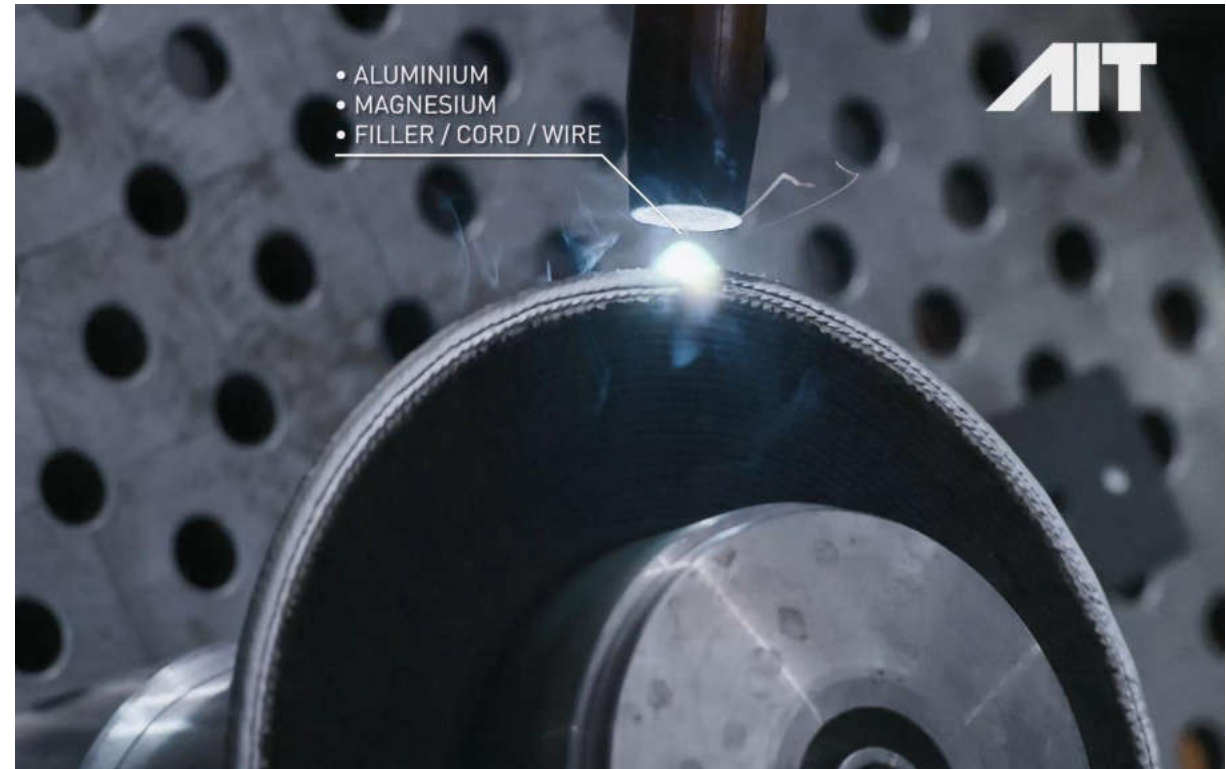

WIRE-BASED ADDITIVE MANUFACTURING

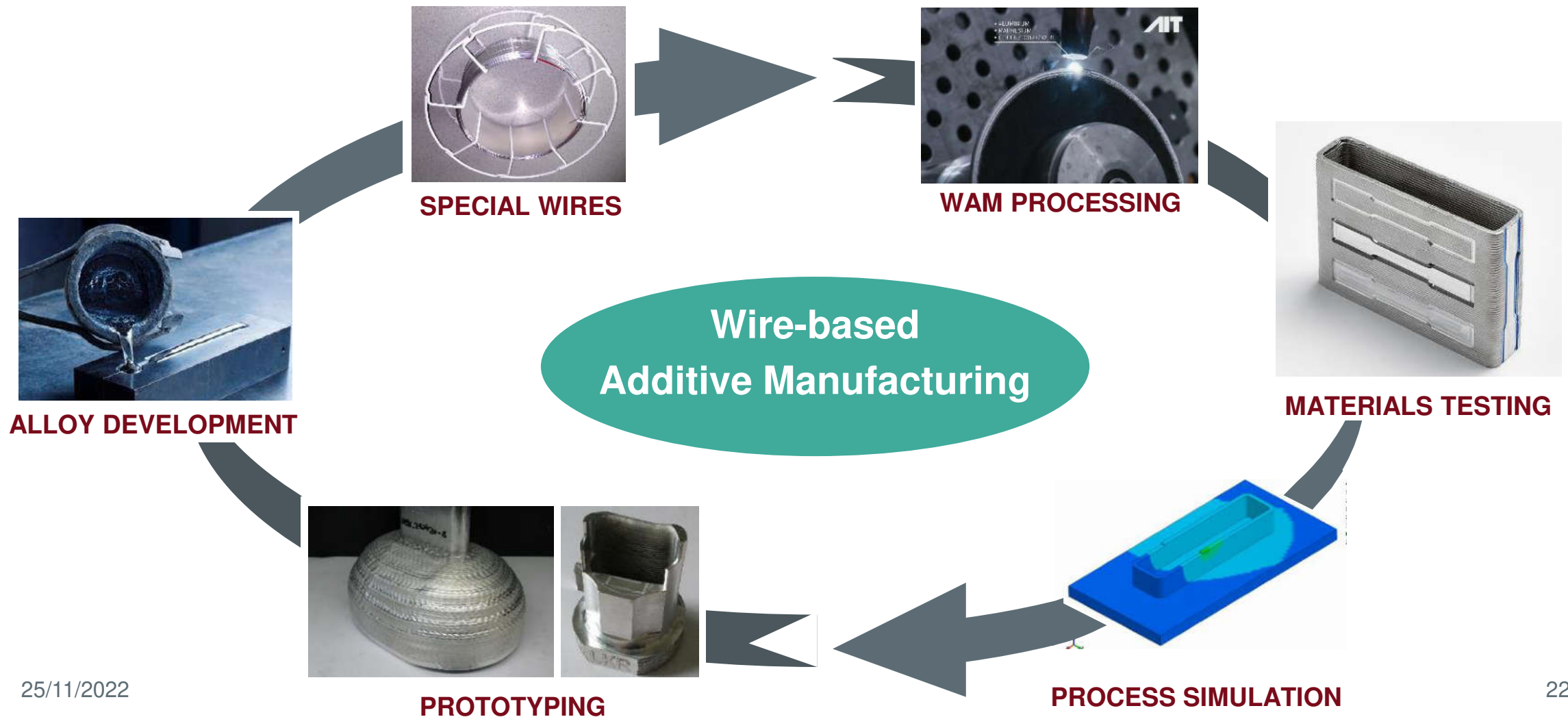

WAM HIGHLIGHTS

AZ91PMD (ESA-De-Risk contract)

Manufacturing of small and medium batch of non-market available AZ91 Mg-alloy, 18 kg

Manufacture of hybrid demonstrators

Modification of HPDC cast tube with spiral and connector features realized by WAM

Compensator Prototype

Prototype of a thermal expansion compensator for a research reactor



Special Wires



Modified HPDC tube

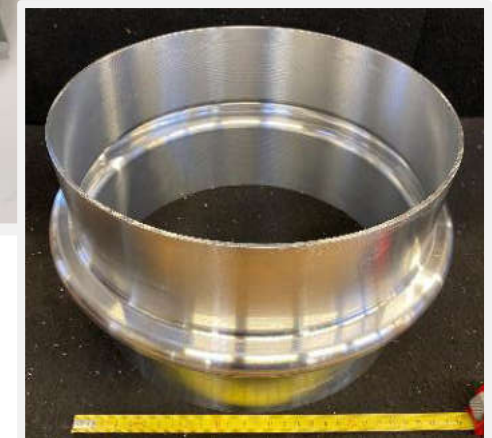

Thermal compensator

RECYCLING UPGRADE

Recycling of mixed scarp from aircrafts

- Melting of 46kg of mixed aircraft scrap (classical melt processing e.g., impeller, skimming)
- Melt yield: 38kg ingot
- total scraping of 4,7kg
- 1.9kg of non-melted material such as titanium sheets, iron rivets, ...
- Chemical mix composition of 2xxx and 7xxx alloy

Ni [%]	Ti [%]	Zr [%]	Cr [%]	Si [%]	Mn [%]	Fe [%]	Mg [%]	Cu [%]	Zn [%]	Al [%]
0,02	0,04	0,06	0,07	0,16	0,25	0,23	1,80	3,01	3,47	90,9



THANK YOU!

Christian Chimani

28/11/2022

